

Genset Control for Auto Start and Transfer Switch Operation (Model "320/350")

DESCRIPTION

I/O's

- 1 or 3 phase generator and mains true rms voltage, measuring inputs: rated 480 Vac (max. 600 Vac)
- Maximum 2 configurable discrete inputs
- Maximum 2 programmable relays
- D+ input (charge alternator input/output)

Protection (ANSI #)

Generator / Engine: Battery voltage, over-speed (12), over-/undervoltage (59/27), over-/underfrequency (810/U), charge alternator failure

Features

- Start/stop sequence for Diesel engines
- Pre-glow control
- Operating hours, service hours, and start counters
- Configurable trip levels/delays/alarm classes
- 6digit 7segment LED for
 - display of measuring values (V, f, speed)
 - display of counters (see above)
 - display of alarms
 - display of ECU messages
- PC and/or front panel configurable (selection of parameters for front panel configuration)
- Password protected front panel configuration
- 15 entry event logger
- Customized display using paper-strips

Differentiation

- Model "320": GCB (generator circuit breaker) operation only
- Model "350": GCB and MCB (mains circuit breaker) operation
- Generator voltage measurement
 - 1phase-2wire
 - Option "X": 3phase-4wire, 3phase-3wire, 1phase-3wire, and 1phase-2wire
- Mains voltage measurement
 - Model "350": 3phase-4wire
 - Model "350X": 3phase-4wire, 3phase-3wire, 1phase-3wire, and 1phase-2wire
- Option "X": Visualization of J1939 messages
- Option "X": MPU input (magnetic/switching)

APPLICATIONS

The easY™gen-320 offers automatic engine starting, stopping, metering, and generator protection (the easY™gen-350 adds AMF and transfer switching). The easY™gen-300 series is designed for single unit isolated operation applications.

The multi purpose 6 digit 7 segment LED offers the ability to display measured values and alarm messages. The CAN bus operation adds the ability to display J1939 messages from an engine ECU.

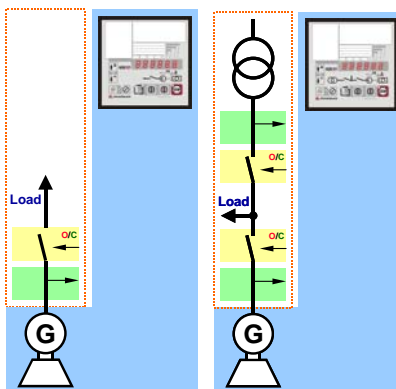

320 & 350
breaker applications

The isolated J1939 CAN bus permits long distance networks for selected ECU manufacturers. Our sales department can provide information regarding the selected ECU manufacturers.

- AMF/loss of mains auto start/stop
- Complete engine and generator protection in one unit
- True RMS sensing of voltage
- Counters for operating hours, service hours, and starts
- Freely configurable discrete inputs
- Freely programmable relay outputs
- PC and/or front panel configurable
- Password protected front panel configuration
- Event logger
- Customized display using paper-strips
- 6.5 to 32.0 Vdc power supply
- Front panel-mounting
- Display of J1939 data
- Visualization of J1939 DM1 / DM2 SPN-FMI error messages
- D+ charge alternator input/output
- CE marked
- Shock and vibration test approved
- UL/cUL listed

SPECIFICATIONS

Power supply 12/24 Vdc (6.5 to 32.0 Vdc)
 Intrinsic consumption max. 10 W
 Degree of pollution 2
 Ambient temperature (operation) -20 to 70 °C / -4 to 158 °F
 Ambient temperature (storage) -20 to 85 °C / -4 to 185 °F
 Ambient humidity 95 %, non-condensing
Voltage (Λ/Δ)
 480 Vac Rated (V_{rated}) 277/480 Vac
 Maximum value (V_{max}) 346/600 Vac
 Rated voltage phase-ground 300 Vac
 Rated surge voltage 4.0 kV
 Linear measuring range 1.3 x V_{rated}
 Measuring frequency 40 (mains) or 15 (generator) to 85 Hz
 Accuracy Class 1
 Input resistance 2.0 MΩ
 Max. power consumption per path < 0.15 W
Speed input capacitive isolated
 Input impedance min. approx. 17 kΩ
 Input voltage 875 mV eff.
D+ input/output
 Max. exciter current 12 Vdc (terminal 4) 0.11 A
 24 Vdc (terminal 3) 0.11 A

Discrete inputs isolated
 Input range 12/24 Vdc (6.5 to 32.0 Vdc)
 Input resistance approx. 6.7 kΩ
Relay outputs isolated
 Contact material AgCdO
 Load (GP) 2.00 Aac@250 Vac
 2.00 Adc@24 Vdc / 0.36 Adc@125 Vdc / 0.18 Adc@250 Vdc
 Pilot duty (PD)
 1.00 Adc@24 Vdc / 0.22 Adc@125 Vdc / 0.10 Adc@250 Vdc
Housing Flush-mount Type Woodward
 Dimensions 158x158x40 mm
 Front cutout 138[+1.0]x138[+1.0] mm
 Connection screw/plug terminals 2.5 mm²
 Tightening torque 0.5 Nm
Housing insulating surface
 Protection system with correct installation
 Front IP54 pending
 Weight approx. 450 g
 Disturbance test (CE) tested according to applicable EN guidelines
Sinusoidal Vibration 4G, 5 to 100 Hz
Endurance Vibration 4G, 30 Hz, 1.5 h
Random Vibration 1.04Grms, 10 to 500 Hz, 2 h
Shock 40G peak, 11 ms
 Listings UL/cUL

DIMENSIONS

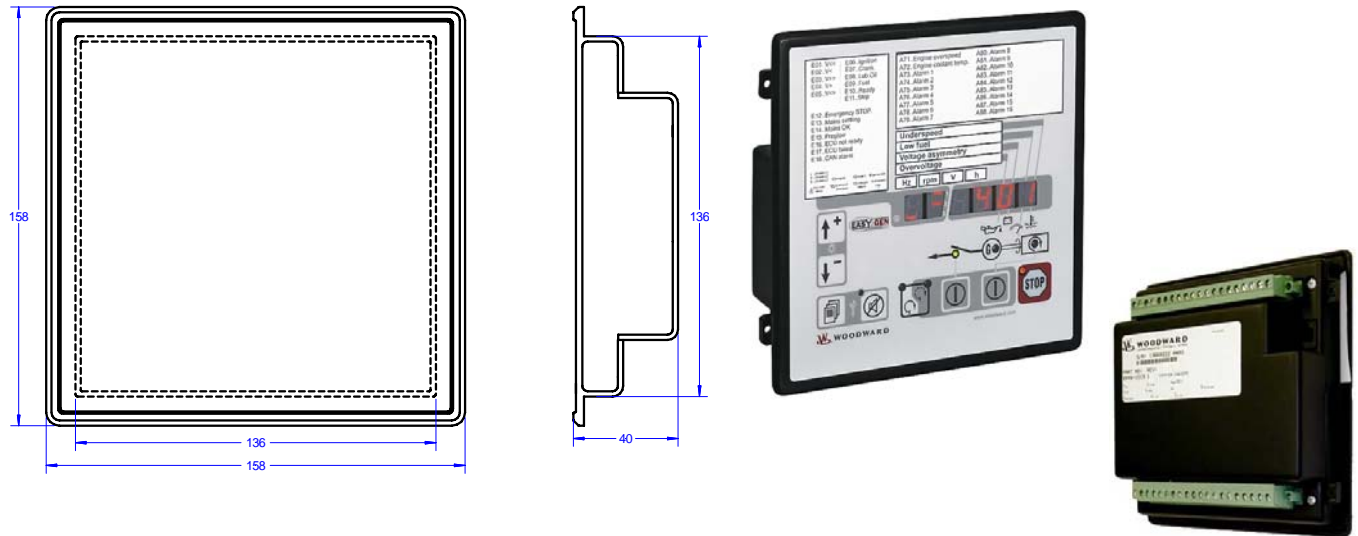

PART NUMBERS

Model	Part Number (P/N)	Description
Model "320"	P/N 8440-1798	EASYGEN-320-50B
Model "320/X"	P/N 8440-1800	EASYGEN-320-50B/X
Model "350"	P/N 8440-1799	EASYGEN-350-50B
Model "350/X"	P/N 8440-1801	EASYGEN-350-50B/X

WIRING DIAGRAMS

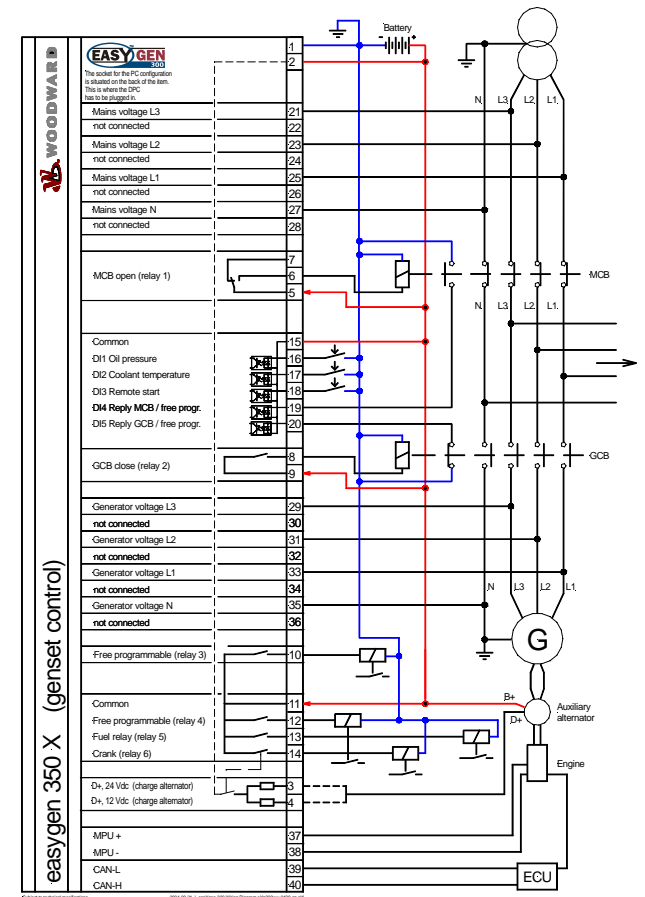
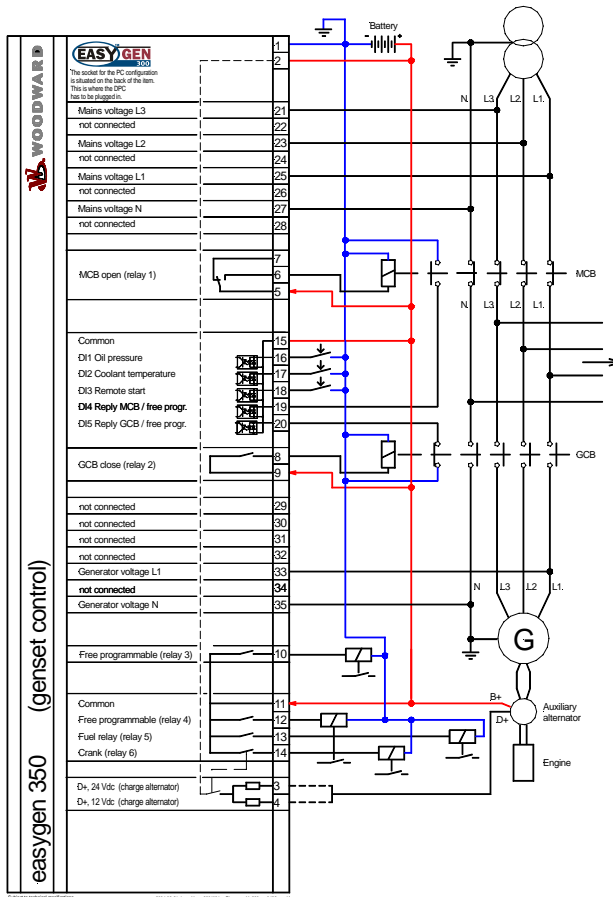
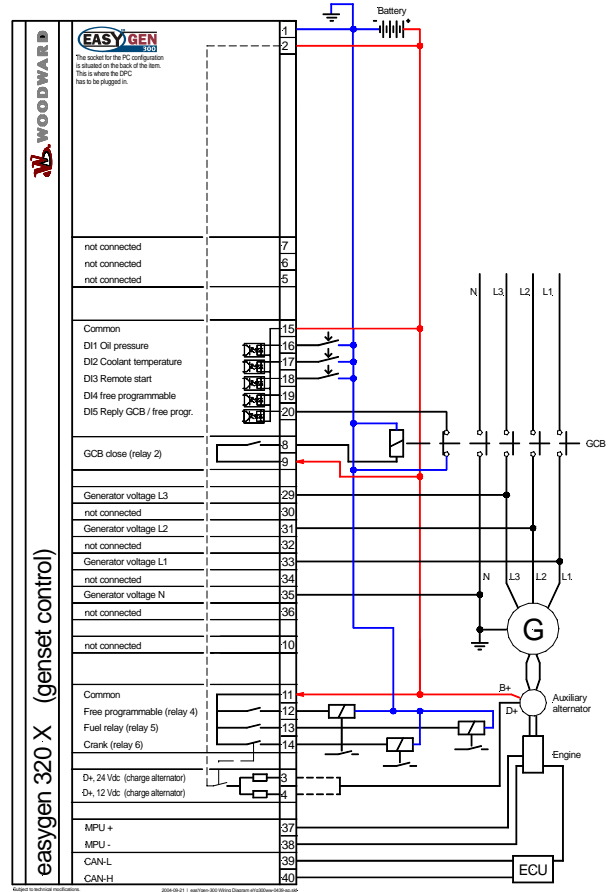
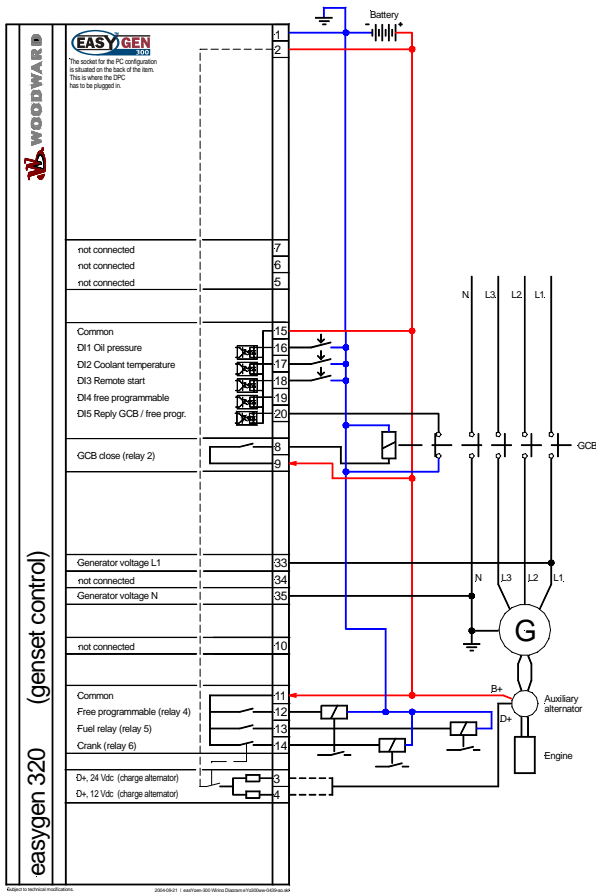

FEATURES OVERVIEW

International
 Woodward
 PO Box 1519
 Fort Collins CO, USA
 80522-1519
 1000 East Drake Road
 Fort Collins CO 80525
 Ph: +1 (970) 482-5811
 Fax: +1 (970) 498-3058

Europe
 Woodward Governor Company
 Leonhard-Reglerbau GmbH
 Handwerkstrasse 29
 70565 Stuttgart, Germany
 Ph: +49 (0) 711 789 54-0
 Fax: +49 (0) 711 789 54-100

Distributors & Service
 Woodward has an international network of distributors and service facilities. For your nearest representative, call the Fort Collins plant or see the World-wide Directory on our website.

Corporate Headquarters
 Rockford IL, USA
 Ph: +1 (815) 877-7441

www.woodward.com/power

For more information contact:

Subject to technical modifications.



This document is distributed for informational purposes only. It is not to be construed as creating or becoming part of any Woodward Governor Company contractual or warranty obligation unless expressly stated in a written sales contract.

We appreciate your comments about the content of our publications. Please send comments including the document number below to stgt-doc@woodward.com

© **Woodward Governor Company**

All Rights Reserved

37217C - 06/3/S

		easY™gen-300			
		320	320/X	350	350/X
					
Measuring					
Generator voltage - true rms	rated 277/480 Vac max. 346/600 Vac	1p-2w	configurable#1	1p-2w	configurable#1
Mains voltage - true rms	rated 277/480 Vac max. 346/600 Vac			3p-4w	configurable#1
Control					
Push-buttons to operate the unit		✓	✓	✓	✓
Isolated single-unit operation		✓	✓	✓	✓
AMF (auto mains failure operation)				✓	✓
Stand-by operation		✓	✓	✓	✓
Open transition (break-before-make)				✓	✓
ATS (automatic transfer switching)				✓	✓
Accessories					
6digit 7segment LED (display of values and alarms)		✓	✓	✓	✓
Global multi-lingual use with customized paper-strip		✓	✓	✓	✓
Start/stop logic for Diesel engines		✓	✓	✓	✓
Operating hours/service hours/start counter		✓	✓	✓	✓
15 entry event logger		✓	✓	✓	✓
Configuration via front panel (password protected)		✓	✓	✓	✓
Configuration via PC #2		✓	✓	✓	✓
Protection					
Engine: over-/underspeed			✓		✓
Generator: voltage/frequency		✓	✓	✓	✓
J1939 DM1 red / amber lamp			✓		✓
I/Os					
MPU input (magnetic/switching; Pickup)			✓		✓
D+ (charge alternator input/output)		✓	✓	✓	✓
Discrete alarm inputs (fixed)		2	2	2	2
Discrete remote start input (fixed)		1	1	1	1
Discrete alarm inputs (configurable) #3		2	2	2	2
Relay outputs (fixed)		3	3	4	4
Relay outputs (configurable)		1	1	2	2
CAN bus communication #4			✓		✓
Listings/Approvals					
CE marked		✓	✓	✓	✓
UL/cUL listed		✓	✓	✓	✓
Shock and vibration test approvals		✓	✓	✓	✓
Part Numbers P/N		8440-1798	8440-1800	8440-1799	8440-1801

#1 Configurable: 1p-2w, 1p-3w, 3p-3w, 3p-4w
 #3 Only available if breaker replies are not used

#2 Cable incl. software necessary (DPC = Part Number P/N 5417-557)
 #4 fixed CAN J1939 (selected ECU manufacturers; request information)

Example for customizable paper strips:

X = Only available in X-Versions	350 = Only available in EasyGen 350/350X	0/1 = Off/On	Alarm Messages:
01 Horn reset time [s]	52 Gen. under freq. [%]	72 Display level	10A Generator overfrequency
10 Rated frequency [Hz]	53 Gen. under freq. [%]	80 Mains settling time [s] (350)	11A Generator underfrequency
11 Gen. rated volt [V]	54 Gen. over volt [%]	81 Mains over volt. [%] (350)	12A Generator overvoltage
12 Mains rated volt [V](350)	55 Gen. over volt [s]	82 Mains under volt [%] (350)	13A Generator undervoltage
20 Fuel relay [0/1]	56 Gen. under volt [%]	83 Mains volt. hysteresis [%] (350)	14A Mains rotation field 350
21 Preglow time [s]	57 Gen. under volt [s]	84 Mains over frequency [%] (350)	20A Engine overspeed (X)
30 Pickup [0/1] (X)	58 Eng. ovrsprd. monit. [0/1] (X)	85 Mains under frequency [%] (350)	21A Engine underspeed (X)
31 Nom. speed [rpm](X)	59 Eng. over speed [rpm](X)	86 Mains freq. hysteresis [%] (350)	30A Start failure
32 No. pickup teeth (X)	60 Batt. under volt [V]	90 J1939 Device type (X)	31A Unintended stop
40 Cool down time [s]	61 Charge fail monit. [0/1]	91 J1939 Request send address (X)	40A Maintenance hours
50 Gen. over freq. [%]	62 Charge fail level [V]	92 J1939 Receive device No. (X)	50A Battery undervoltage
51 Gen. over freq. [s]	71 Reset maint hours [0/1]	93 J1939 Monitoring [0/1] (X)	51A Charge failure
			60A Discrete input 1
			61A Discrete input 2
			62A Discrete input 4
			63A Discrete input 5
			64A J1939 Error (X)